

Diggity Designs XLR8 Set Up Sheet

Date: **9-10-2006** Temp/Air: **75 DEGREES**

Driver: **TEAM DIGGITY DESIGNS**

Track/Race Location: **GRAND RAPIDS MICHIGAN**

Comments: This is a great starting set up for low traction outdoor tracks. Use TC3 or TC4 steering blocks with the inner ackermann location.. Use TC4 rear bearing blocks (you will need to drill a set screw hole). Mount the rear arms in standard format with shocks on the outside.

Sway Bars: Front Rear
 ESC: **KO PROPO VFS-1 PRO** Batteries: **3800's**
 Servo: **JR DZ8450** Body: **PROTOFORM MAZDA 6**

TRACK CONDITIONS

Traction: High Bite Med. Bite Low Bite

Track Difficulty: Technical Open Mixed

Track Surface: Carpet Asphalt

TRANSMISSION SETTINGS

Front Differential	Rear Differential
<input type="checkbox"/> Loose	<input type="checkbox"/> Loose
<input checked="" type="checkbox"/> Medium	<input type="checkbox"/> Medium
<input type="checkbox"/> Medium Tight	<input checked="" type="checkbox"/> Medium Tight
<input type="checkbox"/> Tight	<input type="checkbox"/> Tight

Front One Way Front Solid Diff

Spurgear: **69T 48 PITCH** Pinion: **26-28T**

Motor: **19Turn** Brush: **767 REEDY**

SHOCK SETTINGS

Shocks: Associated Other_____

Associated Front Springs	Associated Rear Springs
<input type="checkbox"/> #3941 Green 12 lbs	<input type="checkbox"/> #3941 Green 12 lbs
<input type="checkbox"/> #3942 Silver 14.5 lbs	<input type="checkbox"/> #3942 Silver 14.5 lbs
<input type="checkbox"/> #3943 Blue 17 lbs	<input type="checkbox"/> #3943 Blue 17 lbs
<input type="checkbox"/> #3944 Gold 19 lbs	<input checked="" type="checkbox"/> #3944 Gold 19 lbs
<input type="checkbox"/> #3945 Red 22 lbs	<input type="checkbox"/> #3945 Red 22 lbs
<input type="checkbox"/> #3946 Copper 25 lbs	<input type="checkbox"/> #3946 Copper 25 lbs
<input checked="" type="checkbox"/> #3947 Purple 30 lbs	<input type="checkbox"/> #3947 Purple 30 lbs
<input type="checkbox"/> #3948 Yellow 35 lbs	<input type="checkbox"/> #3948 Yellow 35 lbs
<input type="checkbox"/> #3949 White 40 lbs	<input type="checkbox"/> #3949 White 40 lbs

Springs Other F_____ R_____

Front Oil: **60WT** Rear Oil: **40WT**

Front Pistons #1 #2 #3 **Rear Pistons** #1 #2 #3

Inner Shock Limiters
 Front: Yes No Rear: Yes No

Outer Shock Limiters
 Front: Yes No Rear: Yes No

TIRES

Foam Tire Size: **2.28** Rubber Tire:

Brand: **NITRO SHOES** Rim:

Front Compound: **40/35** Front Insert:

Rear Compound: **35/30** Rear Insert:

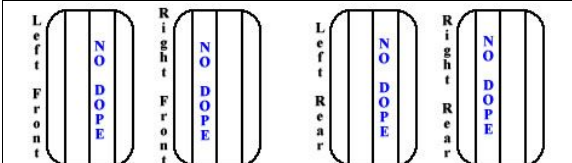

Treated Area (Shade): Additive Type: **NONE**

CAR SET UP

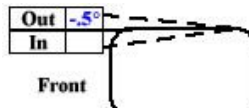
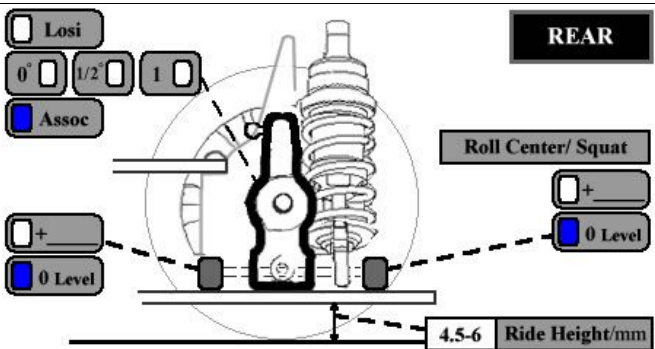
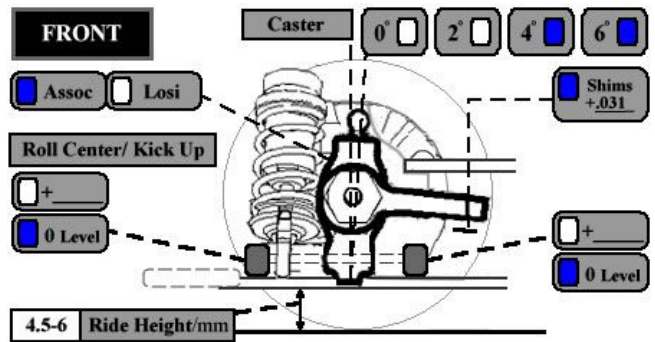

Front Toe-In or Out:

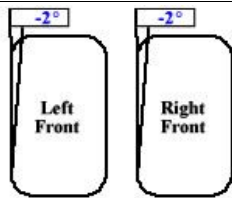

Front Camber:

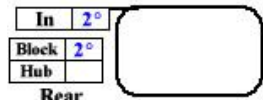

Rear Toe-In:

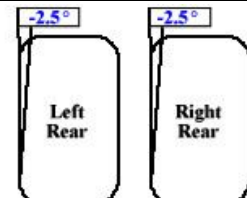

Rear Camber:

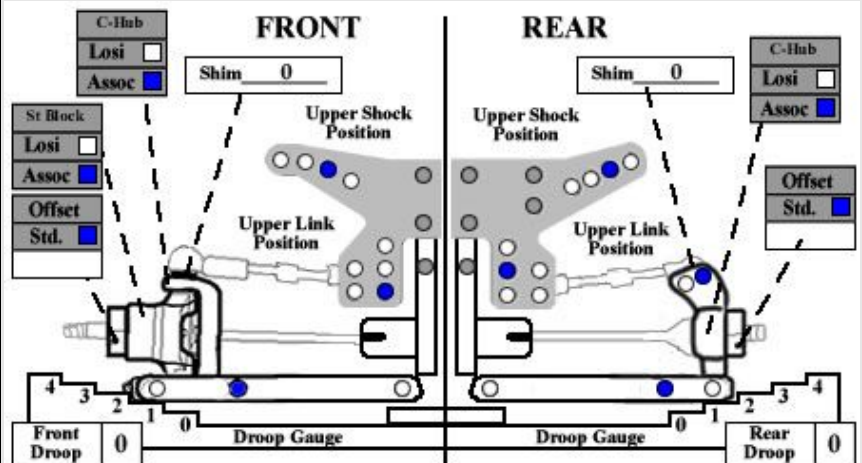

Wheelbase: Long Medium Short